

Chain Conveyors and special Belt Conveyors

For the direct way



Saxlund International offers a wide range of bulk handling equipment including silo systems with discharge machines. All of this is designed for difficult non free flowing bulk solids and is therefore mainly suitable for the cement industry, timber and wood board industries as well as for sludge cake handling in the water industry and indeed many other industries worldwide. The basis of your trust is our knowledge and experience which has been generated over many years.

Trough Chain Conveyor

The Saxlund International chain conveyor is a continuous operating conveyor with a rectangular cross-section. It may be arranged horizontally or inclined. The bulk material is fed at the tensioning station. The conveying chain runs onto a special floor and conveys the material through the upper or lower section to the drive station, where it is dumped or discharged to other conveyor systems. The construction type of the conveyor chain is adapted according to the bulk material. All links are manufactured from high-grade drop-forged steel with welded flights to suit the application. The chain is driven by a chain wheel on a bearing shaft, which, in turn, is driven by a gear motor with an additional roller chain drive.

After material has been dumped, the empty chain runs over the guide rails to the tensioning station. The chain is then returned to conveying direction by the tail wheel. The wheel is situated in a spring loaded slide rest with roller bearing. The springs are arranged on both sides and can be pre-tensioned by means of screwed rods. A sensor to control the idle time at conveyor is situated at the defecting drum.

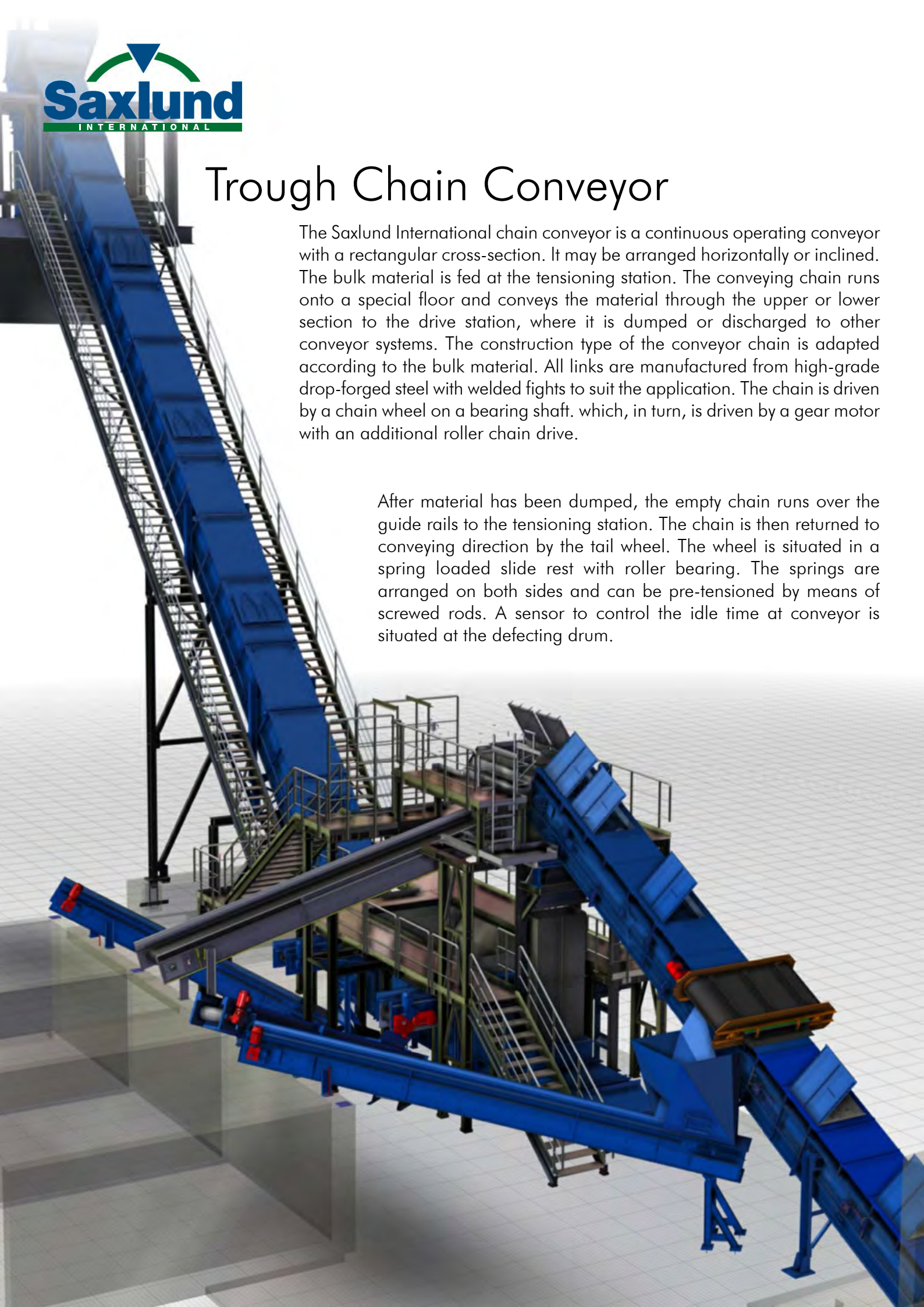

Conveyor chains of high-grade drop forged steel for horizontal and vertical conveying of 102mm till 300mm pitch

- single strand
- twin strand

Pitch:	102	125	142N	142V	160	175	200	250	260	300
Breaking force KN	100	150	300	600	400	600	400	600	900	1000



Single strand link

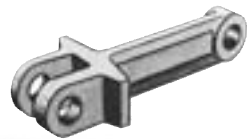

Single strand link with forged cams



Twin strand link



Twin strand link with forged cams



Link for plate conveyors and discharge boxes



Type BT



Type U



Type O



OO-link with rear welded broaching sheets



O-Element with burnt or forged, welded carriers.



Chain wheel, separated design. Toothed flanks are hardened.



Deflecting pulley

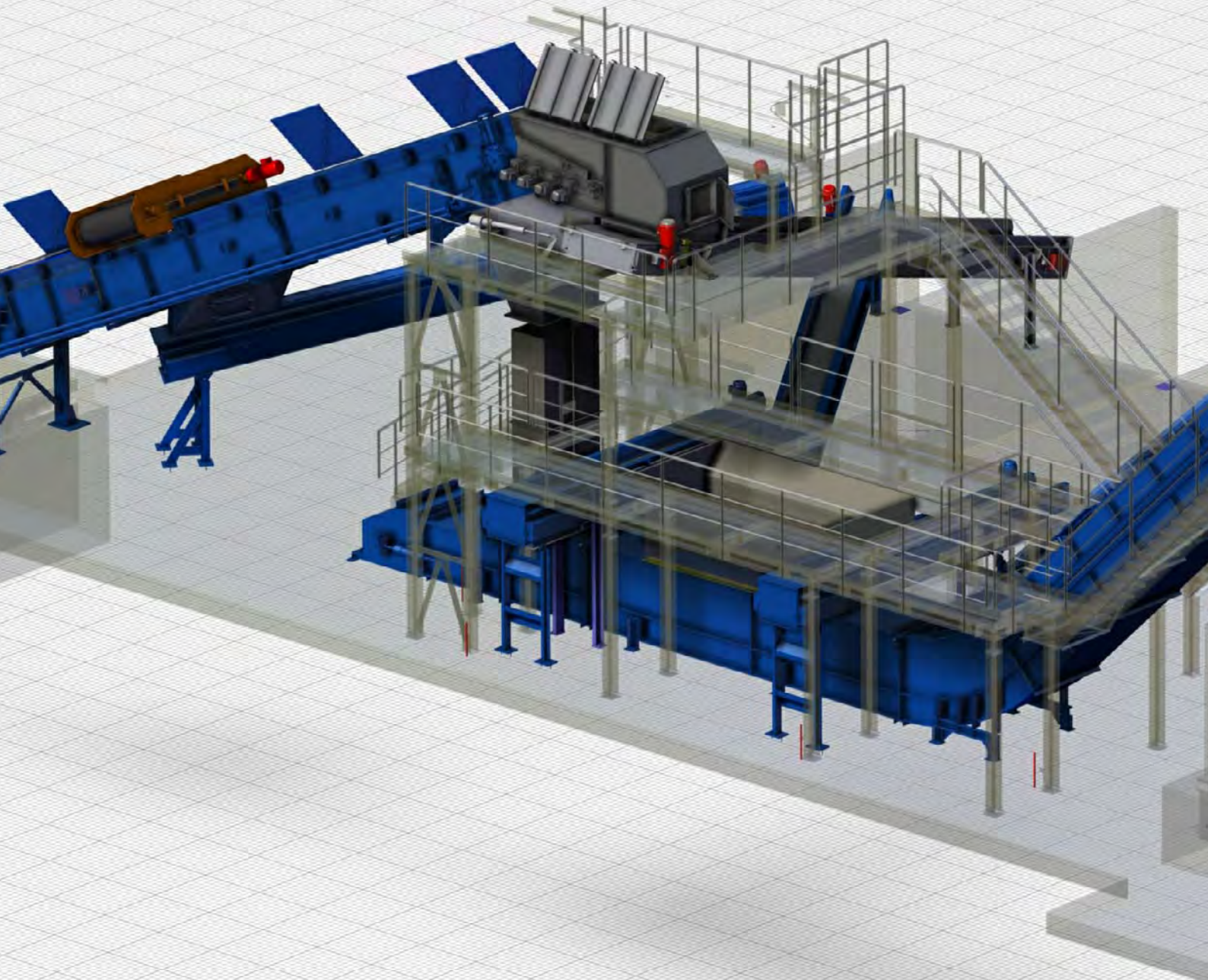



Drive station

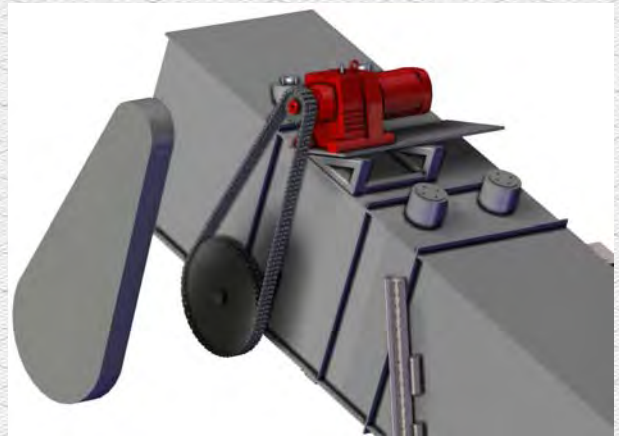

Tensioning station

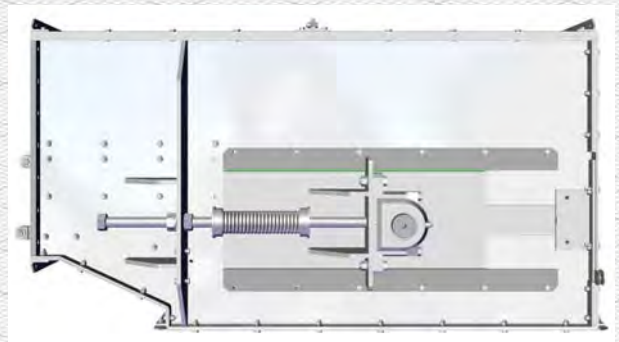

Belt Conveyors

We can supply totally enclosed belt conveyors for special applications. For example, when conveying re-cycled wood or similar biomass fuels to a power generating installation as shown here, there are high specifications to be considered.

- High availability
- Low noise emission
- Fully enclosed machine
- No dust emission
- Lower power consumption

SAXLUND International conveying systems are engineered to fulfill all necessary requirements. Our conveying systems have been proven over many years of operation when running under the most arduous conditions in process industries worldwide. We have the experience and technology to offer the client the most cost effective, energy efficient engineering solution to the particular conveying requirement. Our professional team of engineers look forward to being of services to you.

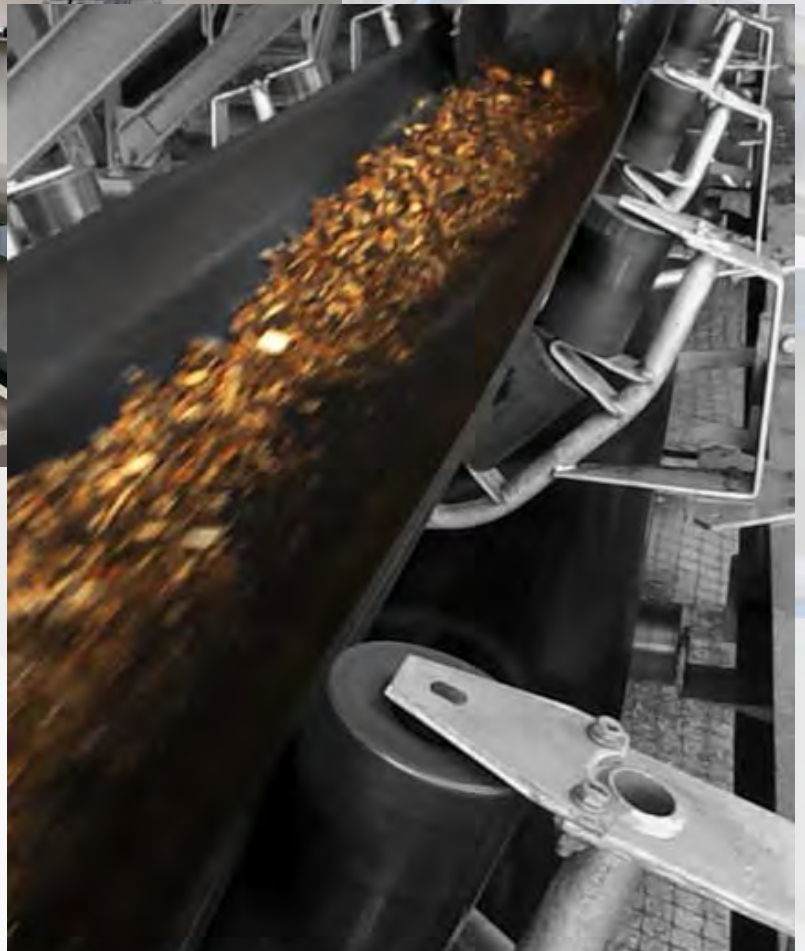



RWE biomass and cogeneration plant in Goch, produce electricity for up to 11.000 households and provided's at the same time, the company „Nähr-Engel“ with up to 130.000 tons of process heat every year.





Address

Saxlund International GmbH
Heidberg 1
29614 Soltau
Germany

Phone

+49 (0)5191 9811-0

Internet

www.saxlund.de

e-mail

info@saxlund.de

Agencies:

Australia
Belgium
China
France
Great Britain
Italy
Japan
New Zealand
Netherlands
Poland
Sweden
Switzerland
Slovak republic
Spain
South Korea
Taiwan
Czech Republic

Products for silo and conveying technology:

- Saxlund Sliding Frames
- Saxlund Push Floors
- TubeFeeder
- Saxlund Rotors
- Saxlund Solids Handling Pumps
- Trough Chain Conveyors
- Screw Conveyors
- Elevators
- Rotary Valves
- Combustion Plants
- Control Systems
- Trailer Docking Station

2018-02-13

